

18M Glove & Barrier Insulated Travel Tower

HT18GB/HT18XGB

FEATURES

- Fully insulated Elevating Work Platform
- Enhanced boom set & new structural fibreglass design for robust structural integrity & reliable insulation properties
- Built to AS1418.10 2004 Elevating work platforms standard
- 360° continuous boom slewing
- Safe working load 350kg
- 132kV insulation rating
- Light & manoeuvrable platform
- Available in 4WD

APPLICATIONS

- LV line network construction & maintenance
- General works in close proximity to power lines
- Ideal for the NBN rollout & other telecommunications projects



RANGE CHART

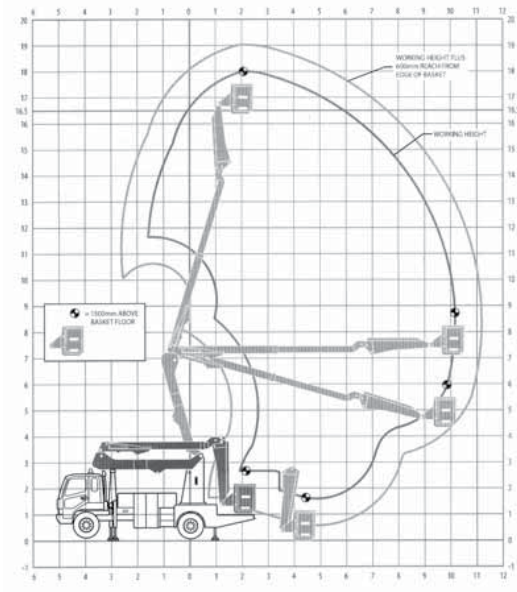

18M GLOVE & BARRIER INSULATED TRAVEL TOWER

SPECIFICATIONS

Type	Vehicle mounted elevating work platform.
Standard	Built to AS1418.10 2004 Elevating work platforms standard.
Operating Height	Rated basket height: 16.5 metres. Working height: 18.0 metres.
Operating Reach	Rated basket reach: 10.5 metres. Working reach: 11.1 metres.
Safe Work Load	350kg
Insulation Rating	132kV ac in accordance with AS1418.10 (interim) 2004. 22kV rated and flame retardant basket with insulated liner. 132kV rated GRP constructed fly boom. 33kV rated GRP coated lower boom (with insulating insert). Basket GRP construction with insulating liner to ASTM D635 standard.
Controls	Basket (main): radio remote. control panel 7.2V dc. Turret (auxillary): manual. Emergency: manual 24V electric retrieval back-up system (from basket & turret).
Luffing	Lower boom, upper boom, telescoping boom, fly boom. Hydraulic operation with self-levelling system.
Slewing	360° continuous slewing. Limited to 5° on any side where stabilisers are not deployed.
Stabilisers	4 x hydraulic operated stabiliser legs with self-levelling feet. 2 x telescoping front stabiliser legs. 2 x fixed rear stabiliser legs.
Prime Mover (Truck)	Approximate Gross Tare: 10,100kg. GMV: 12,000kg.

For more information on how BOOM Sherrin can assist with your access requirements please contact our National Business Development Manager 07 3868 6888 or speak to your nearest branch.

136 132